

Syspend VHD, VHDS Motion Arm

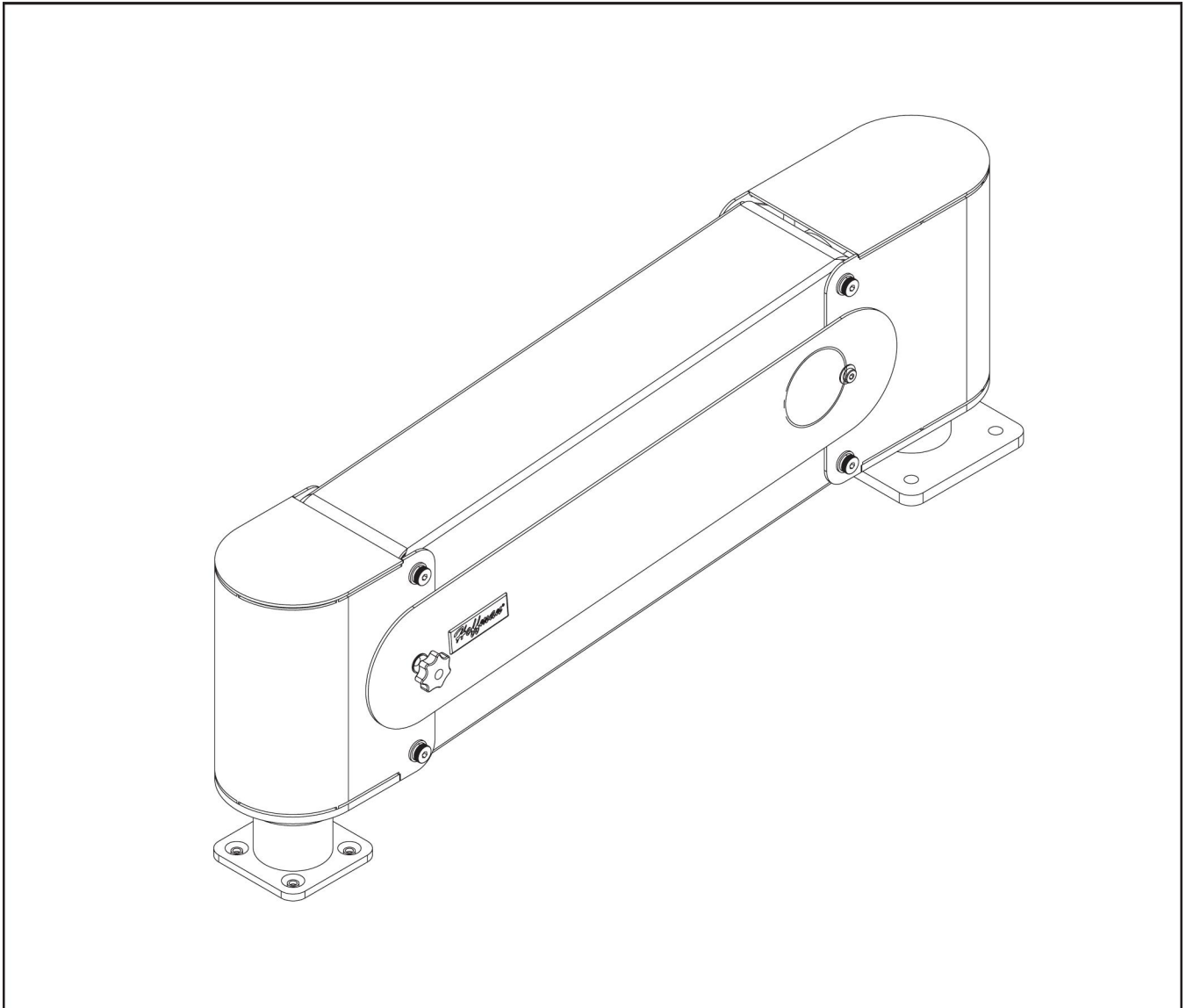

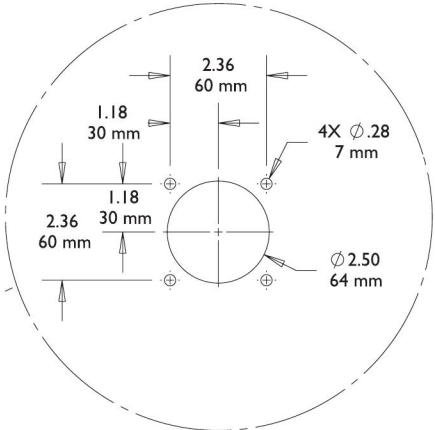
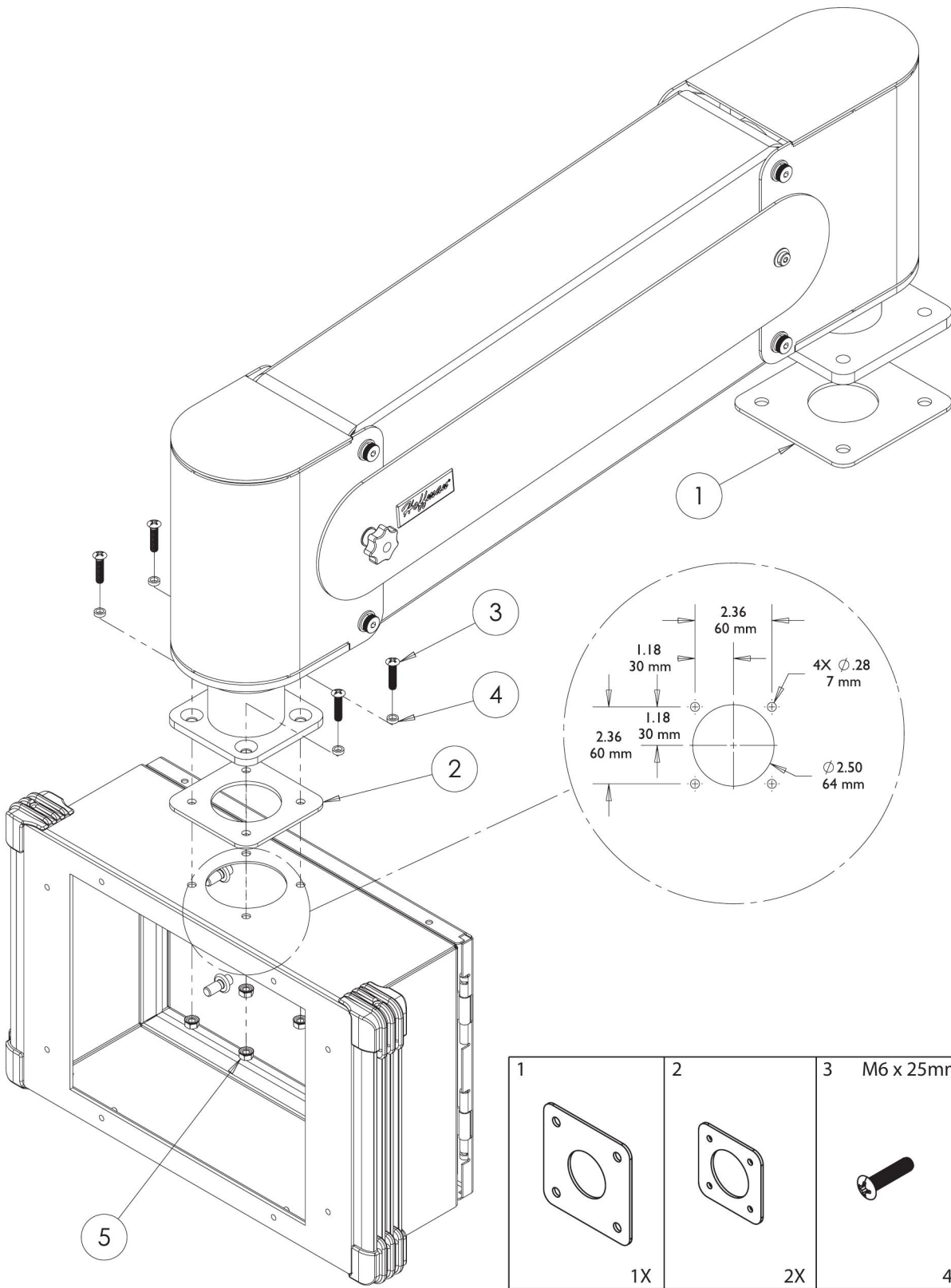

1	2	3 M6 x 25mm	4 M6
1X	2X	4X	4X
5	6 10-24 x .313	7	8 1/4-20 x .75
4X	4X	1X	8X

SYSPEND VHD maintains UL Type 4 or 4X, when installed per mounting instructions.

SYSPEND VHD maintient le Type 4 ou 4X d'UL, une fois installé par instructions de support.

SYSPEND VHD mantiene el Tipo 4 o 4X de la UL, cuando está instalado por instrucciones del montaje.



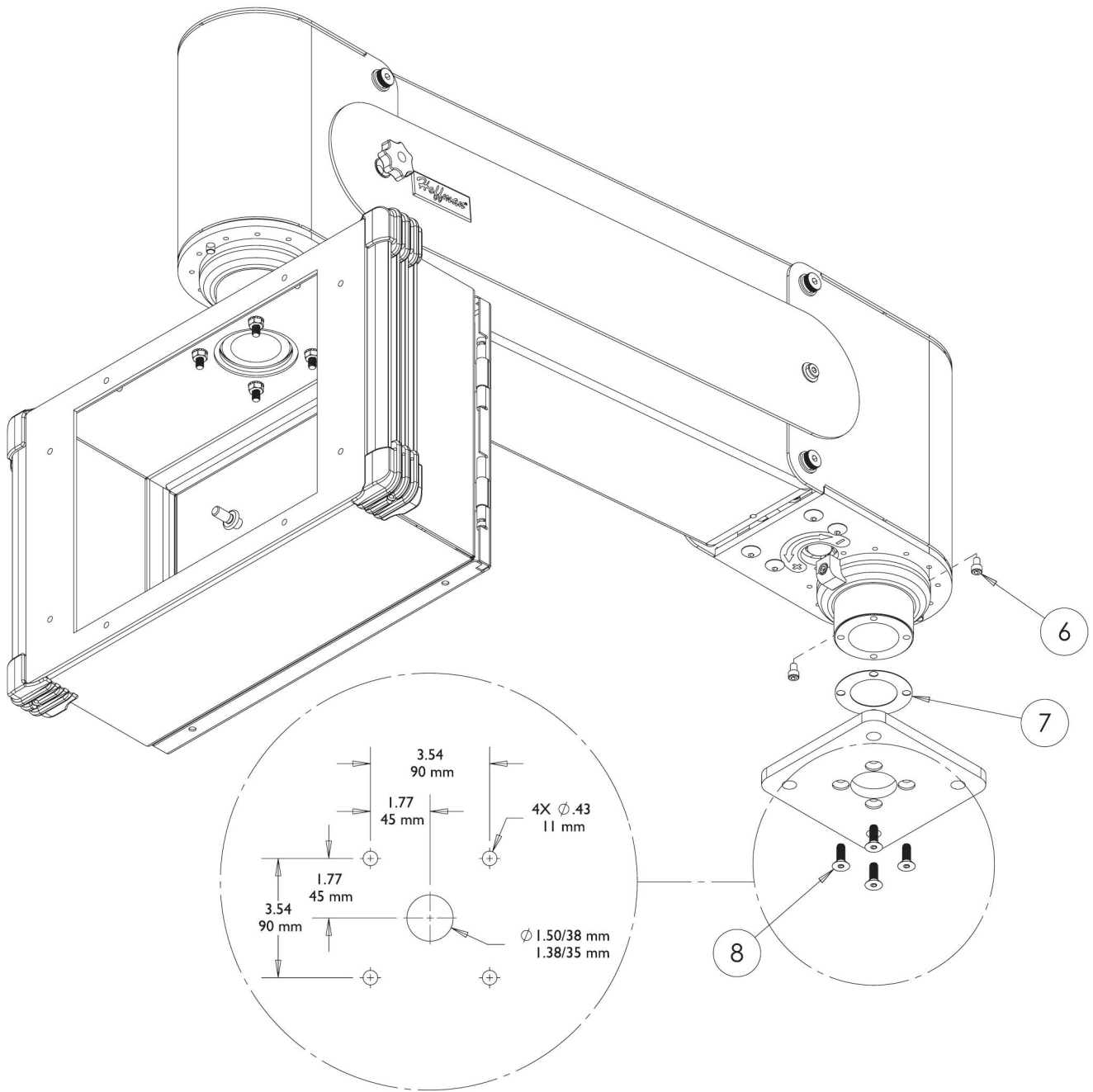

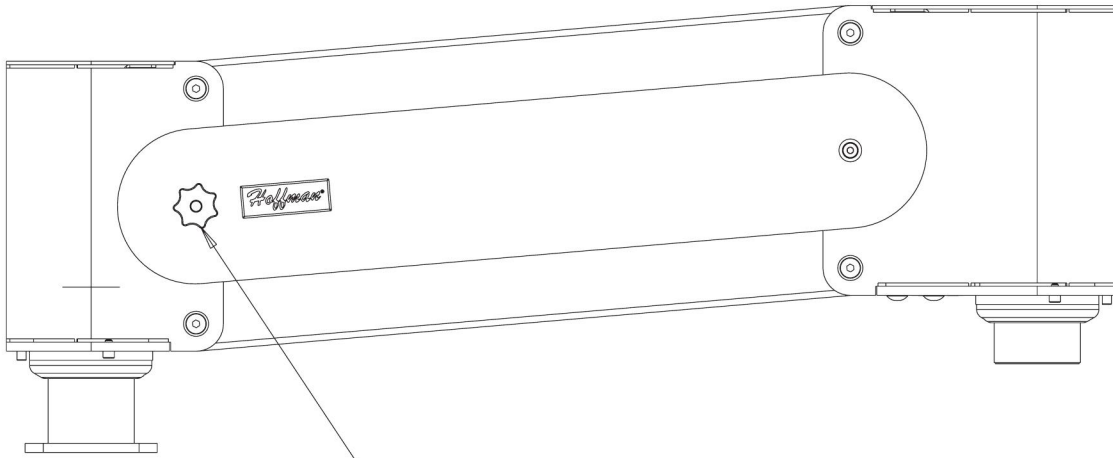

Tighten adjustment knob until desired positions can be maintained
 Serrer la serrure de réglage jusqu'à ce que des situations désirées puissent être maintenues
 Apretar la perilla del ajuste hasta que las posiciones deseadas pueden ser mantenidas

Install #10-24x.313 screws (Item 6) to limit rotation as needed
 Installer les vis #10-24x.313 (point 6) pour limiter la rotation comme nécessaire
 Instalar a tornillos #10-24x.313 (artículo 6) para limitar la rotación según lo necesitado

Turn adjustment screw in + direction until desired balance is achieved
 Tourner la vis de réglage dans + direction jusqu'à ce que l'équilibre désiré soit réalisé
 Dar vuelta al tornillo del ajuste en + dirección hasta que se alcanza el equilibrio deseado

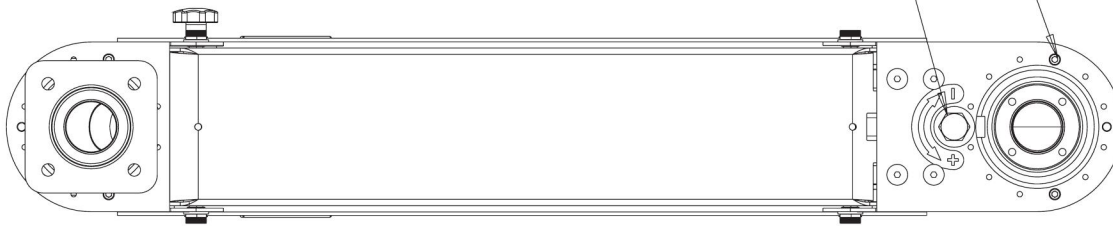

 WARNING
MAXIMUM LOAD RATING 75 LB (34 Kg) AT 36 IN (890 MM) 125 LB (56 Kg) AT 26 IN (635 MM) FAILURE MAY RESULT IN SERIOUS INJURY DO NOT OVERLOAD

AVERTISSEMENT
 CAPACITÉ DE CHARGE MAXIMUM
 75 LB (34 Kg) at 36 IN (890 MM)
 125 LB (56 Kg) AT 26 IN (635 MM)
 L'ÉCHEC PEUT AVOIR COMME
 CONSÉQUENCE DES DOMMAGES SÉRIEUX
 NE PAS SURCHARGER

ADVERTENCIA
 PROMEDIO DE CARGA MÁXIMO
 75 LB (34 Kg) at 36 IN (890 MM)
 125 LB (56 Kg) AT 26 IN (635 MM)
 LA FALTA PUEDE DAR LUGAR A LESIÓN SERIA
 NO SOBRECARGAR

 CAUTION
STRUCTURE AT BASE MUST BE CAPABLE OF SUPPORTING AT LEAST 150LB (68Kg) LOAD AND 220 LB-FT (298 N-m) TORQUE IN ALL DIRECTIONS

ATTENTION
 LA STRUCTURE AU FOND DOIT ÊTRE
 CAPABLE DE SOUTENIR AU MOINS LA
 CHARGE 150LB (68Kg) ET (298 N-m) LE
 COUPLE DE SERRAGE 220 LIVRE-PI
 DANS TOUTES LES DIRECTIONS

PRECAUCIÓN
 La ESTRUCTURA EN LA ESCUADRA BASE
 DEBE SER CAPAZ DE APOYAR POR LO
 MENOS LA CARGA 150LB (68Kg) Y
 EL TORQUE 220 LIBRA-PIES (298 N-m)
 EN TODAS LAS DIRECCIONES